

On the structure of vocatives*

M.Teresa Espinal (Universitat Autònoma de Barcelona)

1. Introduction

In this paper I will focus on the following two questions:

- Q1. What is the internal structure of a phrase interpreted as Vocative?
 Q2. Is it possible to find a syntactic correlation between vocatives and other syntactic structures available in the language?

Although it has been much debated in linguistic theory (Coene et al. 1999; Moro 2003; Hill 2007; D’hulst et al. 2007; Stavrou 2009), the first of these two questions remains to a certain extent still unresolved, at least if we try to account for new data such as those expressions that involve complex vocatives. The second question arises as an attempt to correlate the syntax of vocatives with the syntax of other structures, such as copular sentences (Higgins 1979), in order to challenge the common view that the study of vocatives is not a topic to be addressed as part of the core grammar.¹

I will address these questions within a generative formal syntactic theory, the main ingredients of which are the following: (i) VocP is a functional projection (Moro 2003; Stavrou 2009) whose head Voc° is defined by a deictic [+DX] feature; (ii) Voc° can be specified by a vocative particle, and Voc° selects a DP (see the structure below in (1))²; (iii) second person strong pronouns, which are standardly assumed to be generated in D°, are postulated to move from this position to Voc° in order to be valued appropriately as lexical items referring indexically to the hearer/addressee (see (2))³; (iv) N° movement to D° in the syntax (Longobardi 1994) can be extended to Voc° in order to account for the syntactic and semantic properties of the nominal expression seen in (3a): the bare count nominal is incompatible with the D and denotes a property of the referred second person entity; and (v) a VocP can either occur at the left periphery of a sentential structure (assuming the split Comp field analysis of Rizzi 1997 and Moro 2003) (see (4)), or alternatively, when vocatives do not co-occur with a host structure, a VocP is to be analysed as a disjunct or parenthetical constituent (Espinal 1991), with the structure in (1).

- (1) $[_{\text{VocP}} \text{Part } [_{\text{Voc}^\circ} \text{Voc}^\circ [_{\text{DP}} [_{\text{D}^\circ} \text{D}^\circ] [_{\text{NP}} [_{\text{N}^\circ} \text{N}^\circ]]]]]]$
- $\begin{array}{c} \uparrow \qquad \qquad \qquad \uparrow \\ \text{(iii)} \qquad \qquad \text{(iv)} \end{array}$
- (2) Eh {*tu*, *vosaltres*, *vostè(s)*}!
 PART you.SG.INFORMAL you.PL.INFORMAL you.SG/PL.FORMAL
 ‘Hey! You!’
- (3) a. Ei *company*, com va?
 PART guy how goes
 ‘Hey, man! How are things going?’
 b. *Ei *el company*, com va?
 PART the guy how goes
- (4) C°= ...Force° > (Top° > Foc° > Top° >) Fin°...

In the second part of the article I will turn my attention to some significant structural similarities that hold crosslinguistically between vocatives and copular sentences. Following Higgins’ (1979) claim that copular sentences are not uniform, I will argue, based on data such as (2), (3), and (5), that vocatives are not a peripheral phenomenon in the syntax of natural languages, and that three of the four types of copular sentences postulated by Higgins are found among vocative structures as well, namely the identity,

the identificational, and the predicational types. What these three types of structures have in common is that the subject (i.e., the vocative head) is always referential, while the predicate (i.e., the subsequent NP or DP) is either referential, identificational, or predicational, respectively (compare the three examples in (5)).

- (5) a. Tu! *Joan!* *identity*
 ‘You! Joan!’
 b. Tu! *el noi de la camisa blava!* *identificational*
 you the boy of the shirt blue
 ‘You! The boy in the blue shirt!’
 c. Tu! *noi!* *predicational*
 ‘You! Boy!’

It will be shown that although vocatives are not arguments of verbal predicates (Longobardi 1994; Moro 2003; D’hulst et al. 2007), they can be arguments of nominal predicational structures (5c), as is the case of copular sentences. However, vocative expressions differ from the latter in that they never show an overt copula verb. This parallel I will postulate between vocative structures and copular structures will allow me to extend the proposed analysis to additional data from English.

This paper is organized as follows. Section 2 presents the data, basically from Catalan, and the hypotheses that will be argued for in the rest of the article. Section 3 discusses the syntax of vocative structures and introduces a distinction, which is syntactically and semantically motivated between “true” deictic vocatives and “fake” vocatives. Section 4 is devoted to an analysis of complex structures, those that combine true and fake vocatives, and will show their parallel with copular sentences, from both a syntactic and a semantic perspective. Finally, Section 5 presents the conclusions and the predictions to be drawn from them.

2. The data: vocatives in Catalan

Vocatives are nominal expressions that sometimes designate straightforwardly the hearer(s) or addressee(s) (see (2) and (6a)), sometimes provide the identity or identification of the hearer(s) / addressee(s) (6b), and other times denote properties that call the attention of the hearer(s) / addressee(s) to whom the property denoted by N is attributed (see (3a) and (6c,d)).

- (6) a. *Joan!*
 ‘Joan!’
 b. Tu, *{Joan, el Joan}!*
 you.SG.INFORMAL Joan the Joan
 ‘You, Joan!’
 c. *Senyor!*
 ‘Sir!’
 d. *Vostè,* *senyor!*
 you.SG.FORMAL sir
 ‘You, sir!’

The problem with this set of examples is that intuitively we have different possible candidates for the category vocative, namely a second person pronoun, a proper name, and a common noun. We must therefore examine in some detail the constituents that can occur in these sequences as well as their properties in order to advance a hypothesis about the structure of vocatives.

As already advanced in (2), one group of nominal expressions that occur as vocatives is made up of second person strong pronouns, optionally preceded by a vocative particle (Catalan *ei*, *eh*) which, according to Hill (2007), are particles of

address that call the attention of the hearer.⁴ Note that any of the possible sequences in (7c) are ungrammatical because the particle precedes either a first person or a third person strong pronoun, and (7d) vs. (7d') is ungrammatical because the particle cannot occur in postnominal position unless prosody indicates that the second person pronoun has moved further to the left periphery of the vocative particle. This last example also illustrates the fact that only one vocative particle per utterance is permitted.

- (7) a. Ei tu!
PART you.SG.INFORMAL
b. Eh vosaltres!
PART you.PL.INFORMAL
c. *{Ei,eh} {jo, ell}
PART I he
d. *(Eh) vosaltres eh d'. Vosaltres, eh!
PART you.PL.INFORMAL PART YOU.PL.INFORMAL PART

A second group of nominal expressions that may occur in vocatives is constituted by proper names, bare singulars, and bare plurals, optionally preceded by a vocative particle. As illustrated in (8), these vocative expressions are N heads that must be distinguished from full DPs (Longobardi 1994), whether definite or indefinite.⁵ Regarding (8c,d) it should be noted that in Catalan, as in Greek (Stavrou 2009) and certain German dialects (Schaden 2010), a N in vocatives, in contrast to exclamatives and declaratives, cannot be preceded by a definite article. The contrast between (8c,d) and (8c',d') is due to the fact that the structural position of the DP in each pair of sequences is not the same. For the time being it should be noted that in (8c-e) the Voc particle is intended to specify the full DP and the sequence is fully ungrammatical, whereas in (8c'-d') the Voc particle specifies a null vocative and the full DP occurs in a complement position of Voc. Nominal expressions in vocatives are not number-neutral since they either refer to an individual entity if singular or refer to a set of individuals if plural, and they neither accept an existential reading nor a kind-generic interpretation.

- (8) a. Ei Joan!
PART Joan
b. Eh company(s)!
PART guy(s)
c. *Ei el Joan!
PART the Joan
d. *Eh el company!
PART the guy
e. *Eh un(s) company(s)!
PART {a, some} guy(s)
c'. Ei, ##el Joan!
PART the Joan
d'. Eh, ##el noi ros
PART the boy blond

It should also be noted that these nominal expressions can be followed by a declarative, an imperative or an interrogative clause. Example (9c) differs from (9a,b) not only in the force of the sentence, being interrogative, but also in having a collective noun instead of a common count noun in vocative position.

- (9) a. Ei tio! M'agrada la samarreta que portes.
PART pal me.likes the T-shir that wears
'Hey, man! I like your T-shirt.'
b. Ei nois! Calleu!
PART boys shut
'Hey! Boys! Shut up!'
c. Eh canalla! Què tal?
PART kids how that
'Hey, kids! How are things?'

All these examples make salient the fact that bare nominal vocatives introduce a series of mismatches at the syntax-semantics interface, because in spite of disallowing a Determiner they are well-formed in the initial position of the clause.⁶ That is, count bare nominals can occur in vocative contexts even though they are not arguments of the verbal predicate of the host structure (Longobardi 1994; Moro 2003; Corver 2008), which suggests that being deictic, as the nominal vocatives in (9) are, should not be confused with being argumental. On the other hand, nominal vocatives have an ostensive-deictic interpretation, even though common count nouns, unlike proper names, are property-denoting expressions.

A third group of lexical items that can occur in vocatives are bare adjectives, optionally preceded by a vocative particle. These vocative expressions are A heads that denote properties of token individuals, and predicate deictically on the hearer(s) / addressee(s), quite similarly to the bare nouns in (8b) and (9a-c). See (10).

- (10)a. Ei *jove!* On vas?
 PART young.SG where go
 ‘Hey, young man! Where are you going?’
 b. Eh *desgraciats!* Marxeu de casa meva!
 PART bastards.PL leave from house mine
 ‘Hey, you bastards! Get out of my house!’

Related to the abovementioned contrasts between (8c-c’) and (8d-d’), in Section 4 I will provide an explanation for (11b), which shows a postnominal predicational adjective. The wellformedness of (11b), in contrast to (11a), is due to the fact that the A does not compete for the same position as the 2P pronoun.

- (11)a. *Eh *vosaltres desgraciats!*
 PART you bastards.PL
 b. Eh *vosaltres, desgraciats!*
 PART you bastards.PL

It might also be the case that certain adjectives (such as *benvolgut*, *stimate*, *caro* in (12)) occur as specifiers of DPs that are interpreted as non-deictic predicational vocatives. See (12).

- (12)a. *Benvolgut* amic meu, ... [CATALAN]
 dear friend mine
 ‘My dear friend’
 b. *Stimate* cititorule, ... [ROMANIAN] (Hill 2007:ex.(12e))
 respected.VOC reader.the.VOC
 ‘Dear reader’
 c. *Caro* amico, vieni a trovarmi. [ITALIAN] (Longobardi 1994:ex.(7a))
 dear friend come to visit.me

With these data in mind, I would like to put forward the following three hypotheses:

H1. A distinction should be made in the syntax of vocative structures between “true” and “fake” vocatives.

H2. In “true” vocatives, second person strong pronouns, proper names, bare nominals, and bare adjectives, immediately specified by an optional Voc particle, occur in Voc^o and are interpreted as deictic, either because 2P pronouns and proper names directly designate the hearer(s) / addressee(s), or because bare nominals and bare adjectives introduce a property predicated on the hearer(s) / addressee(s) that points to him/her/them.

H3. In “fake” vocatives a full DP (or QP), very exceptionally specified by a Voc particle, enters into a syntactic relationship with Voc^o (either as Spec,VocP or as Spec,DP c-commanded by Voc^o), and may be associated with either a predicational_T or a referential interpretation.

In the next section I will focus on the syntactic structures to be associated with these nominal expressions.

3. The syntax of vocative structures

VocPs can either occur at the left periphery of a sentential structure, above Force (see the split Comp field analysis in Rizzi 1997 and Moro 2003) as seen in (4), repeated here.

(4) C^o = ... Force^o > (Top^o > Foc^o > Top^o >) Fin^o ...

or, alternatively, when vocatives do not occur with a host structure, they can be analysed as disjunct / parenthetical constituents (Espinal 1991). In this case the VocP is not integrated syntactically in any host structure as seen in (1), repeated here.

(1) [_{VocP} Part [_{Voc'} Voc^o [_{DP} [_{D'} D^o [_{NP} [_{N'} N^o]]]]]]]

The examples in (9) illustrate clearly that vocatives can co-occur at the left periphery of declaratives, imperatives, and interrogatives. Therefore, in this paper, regarding its external structure, a VocP is postulated in [Spec,ForceP] and the Voc particle in its turn is conceived as the Spec of Voc^o.⁷ Taking into account the data presented so far, I would like to postulate that the data support the structure in (13).

(13) [_{ForceP} [_{VocP} {*ei, eh*} [_{Voc'} [_{Voc^o}]...]] [_{Force'} [_{Force^o} {decl, imper, inter}]...]]

With regard to its internal structure, I would like to claim that vocatives are nominal, since they are direct forms of address that take a DP with a canonical structure (Chierchia 1998; Longobardi 2001, 2005; Zamparelli 1995) as its complement. (14) differs from (1) only in the fact that it specifies the two lexical items that can be used as vocative particles in Catalan and the projection of Number between N and D.

(14) [_{VocP} {*ei, eh*} [_{Voc'} [_{Voc^o}] [_{DP} D^o [_{NumP} Num^o [_{NP} N^o]]]]]]]

An argument in support of this structure comes from Moro's (2003: 259) coordination test. See the data in (15), which show that Voc particles cannot be conceived as heads of Voc^o and must be postulated separately from the DP complement of Voc^o.

- (15)a. *Ei, Joan i Maria, acosteu-vos.*
 PART Joan and Maria come.closer.you
 'Hey, Joan and Maria, come closer to me.'
 b. **Ei Joan i ei Maria acosteu-vos.*
 PART Joan and PART Maria come.closer.you

In accordance with what has been said in the literature about vocatives, I assume that Voc^o is defined by a deictic interpretable feature [+DX], and that vocative particles specify a deictic expression, by default a 2P strong pronoun. Vocative particles can also specify a N (or an A) when this N (or A) has a deictic interpretation.

In order to account for the data I also assume an extension of N-raising (Longobardi 1994) to common nouns (Coene et al. 1999). In fact, as has already been pointed out in the literature (Cabredo-Hofherr 2009), this N^o-to-D^o movement is relevant when considering French vocatives, which is something that we do not expect

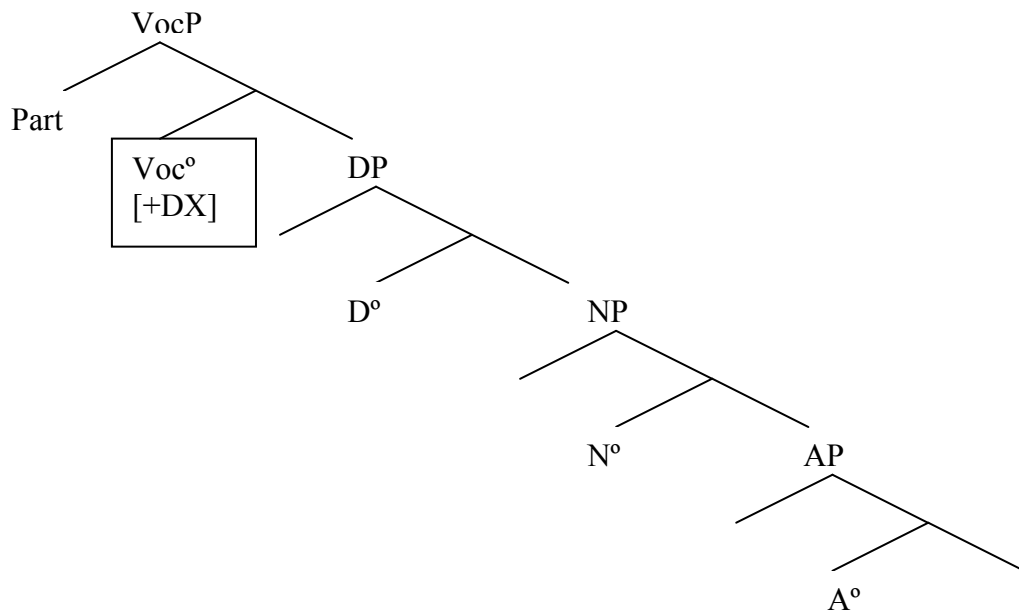

Unlike first and third person pronouns (see (7c)), only 2P pronouns, specified by [+II,-I] person grammatical features and defective for a deictic feature [+DX], satisfy the requirement of being forms of direct address to the hearer / addressee (Hill 2007). Other nominal heads (proper names, common nouns) and adjective heads are assumed to move to a probe deictic Voc° in the process of the derivation in order to guarantee its deictic interpretation.

On the other hand, “fake” vocatives, which are full DPs associated with either a referential or a predicational meaning, as exemplified in (12) and (20) respectively, cannot occur in Voc° , since they are not heads.

- (20)a. Au travail, *les filles!* [FRENCH](Cabredo-Hofherr 2009:ex. (12a))
to work the girls
b. *I protoetis fitites,* elate edo. [GREEK] (Stavrou 2009:ex.(57a))
the first.year students come here
c. *Tots vosaltres,* veniu! [CATALAN]
all you come

The example in (21a), represented in (21b), contains a null Voc° marked with the formal feature [+DX] c-commanding a full DP. In this Romanian example the Voc head is specified by a particle in $VocP$. A similar structure would be postulated for (8c'-d') in Catalan.

- (21)a. Măi *dragă băiatule / băiete,* nu intelegi nimic.¹¹
PART dear boy.the.VOC boy.VOC NEG understand nothing
‘My dear boy, you don’t understand anything!’

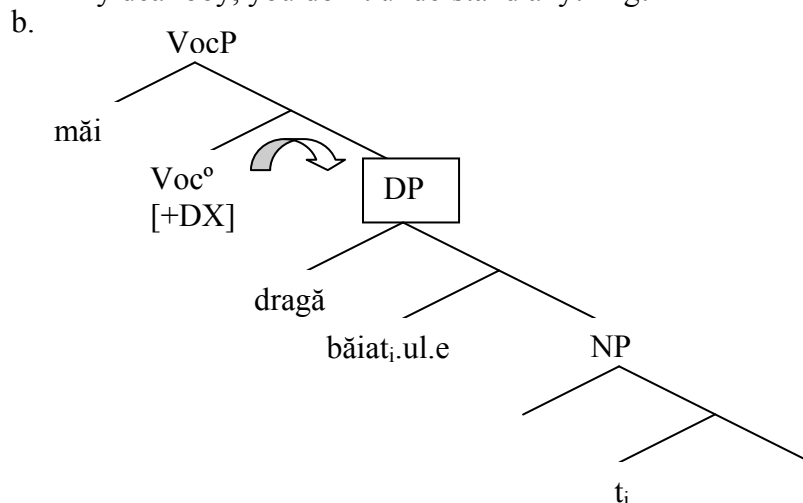

Once we have considered the basic structure of “true” and “fake” vocatives, in the next section we shall consider the structure that should be associated with more complex vocatives in which two nominal expressions combine in a specific order (see (6b,d).

4. Complex vocatives

The question that will be addressed in this section is Q2, but before addressing it we must consider which of the following nominal expressions in each example ought to be considered the “true” vocative, and what its interpretation must be.

(22) CATALAN

- a. *Tu, Joan!* - strong pronoun + proper name
 you Joan
- b. *Tu, el noi de la camisa blava!* - strong pronoun + DP
 you the boy of the shirt blue
- c. *Tu, {nen, desgraciat}.* - strong pronoun + bare {noun, adjective}
 you kid bastard

According to what have seen so far, the most immediate answer seems to be that the “true” vocative expression is precisely the 2P pronoun because it is the best candidate to deictically designate the individual entity it refers to. Only 2P pronouns, specified by [+II,-I] person grammatical features and defective for a deictic feature [+DX], satisfy the requirement of being forms of direct address to the hearer / addressee and show the possibility of combining with other nominal expressions in complex vocatives.

Thus, following a 2P pronoun, the “true” vocative expression, proper names (22a) are no longer true vocatives but instead expressions that provide the *identity* of the entity associated with the addressee. Full definite DPs (22b) provide the *identification* of the entity associated with the addressee. Bare nominals and bare adjectives (22c) are NPs and APs that introduce *predicational* information on the addressee. This classification suggests that there is an important similarity between vocatives and copular sentences.

Let me remind the reader that, according to Higgins (1979), four types of copular sentences can be distinguished in English. See Table 1.

Type	Subject	Predicate
<i>Identity</i>	Referential	Referential
<i>Identificational</i>	Referential	Identificational
<i>Predicational</i>	Referential	Predicational
<i>Specificational</i>	Superscriptional	Specificational

Table 1.

English sentences that instantiate each type are illustrated in (23) (Alexiadou 2005: ex.(67)).

- (23)a. The Morning Star is the Evening Star. *Identity*
 b. That man over there is John Smith. *Identificational*
 c. Paul is sick. *Predicational*

- d. What I don't like about John is his tie. *Specificational*

What I would like to do next is to extend this typology to vocative expressions, since in complex vocative structures we can identify a “true” vocative expression, usually the 2P pronoun, and an additional “fake” vocative, either a proper name, a DP, an NP, or an AP. It should be noted, however, that vocative constructions are distinct from copular sentences in (i) not having a copula verb, and (ii) lacking the specificational type since the head is not cataphoric but deictic. Nevertheless, they are similar in that they relate nominals in subject-predicate structures, as represented in (24).

(24)

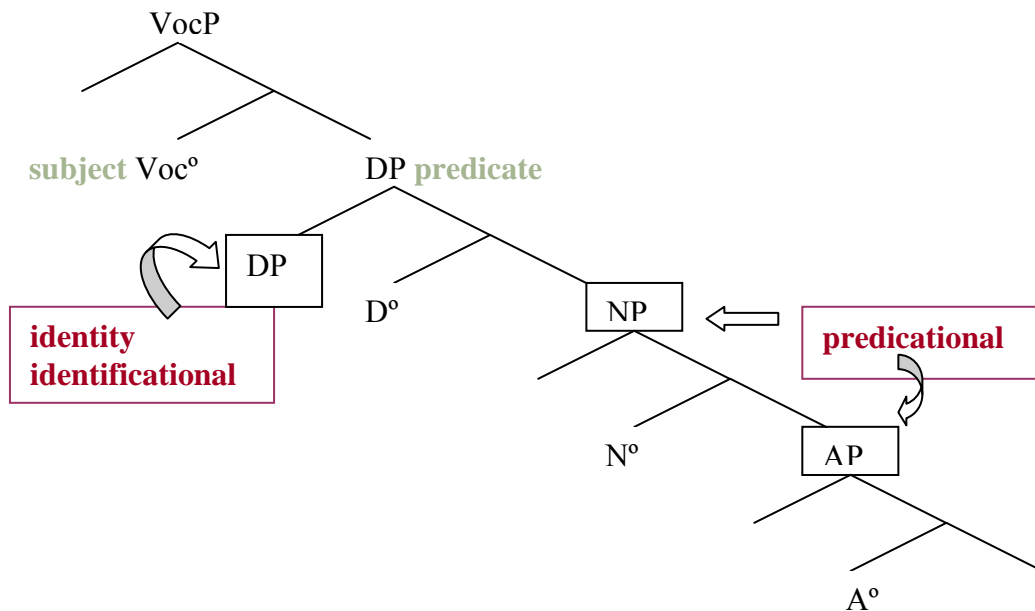

The extension from copular sentences to vocative expressions is illustrated in (25), (26), and (27). In (25a) we exemplify an identity complex vocative made up of a 2P pronoun followed by a bare proper name; according to the syntactic analysis put forward so far the structure associated with this example is represented in (25b), and (25c) gives an English example parallel to the Catalan one. The examples and structures in (26) correspond to an identificational complex vocative. Note that example (26b) differs from (25a) in that the proper name does not move to D°; therefore, in (26c,d), in contrast to (25b), the noun remains in N° and D° is overtly realized by a definite article. Finally, (27) contains examples of predicational complex vocatives, characterized by a 2P pronoun followed by either bare common count nouns (27a) or bare adjectives (27b); their structures are illustrated respectively in (27c,d). English correlates are given in (27e,f).

- (25)a. *Tu, Joan!* *Identity*
 b. $[_{\text{VocP}} [_{\text{Voc}^\circ} tu_i] [_{\text{DP}} [_{\text{DP}} [_{\text{D}^\circ} Joan_j] [_{\text{NP}} [_{\text{N}^\circ} t_j]]] [_{\text{D}^\circ} t_i]]]$
 c. You John, come here!
- (26)a. *Tu, el noi de la camisa blava!* *Identificational*
 b. *Tu, el Joan!* vs. (26a)
 c. $[_{\text{VocP}} [_{\text{Voc}^\circ} tu_i] [_{\text{DP}} [_{\text{DP}} [_{\text{D}^\circ} el] [_{\text{NP}} [_{\text{N}^\circ} noi] [_{\text{PP}} de\ la\ camisa\ blava]]] [_{\text{D}^\circ} t_i]]]$
 d. $[_{\text{VocP}} [_{\text{Voc}^\circ} tu_i] [_{\text{DP}} [_{\text{DP}} [_{\text{D}^\circ} el] [_{\text{NP}} [_{\text{N}^\circ} Joan]]] [_{\text{D}^\circ} t_i]]]$
 e. You, the boy with the blue shirt, come here!
- (27)a. *Tu, {noi, violí primer, foca}!* *Predicational*

- b. *Tu, {desgraciat, idiota}!*
- c. [VocP [Voc° *tu*_i] [DP [D° *t*_i] [NP [N° *noi*]]]]]
- d. [VocP [Voc° *tu*_i] [DP [D° *t*_i] [NP [N°] [AP [A° *desgraciat*]]]]]]]
- e. You, {boy, first violin, (great big beautiful) babe}.
- f. You {bastard, idiot}!

All these examples and representations illustrate the fact that complex vocatives combine a “true” vocative, hosted in Voc°, with a “fake” vocative, located either in a specifier DP position or in a subordinate NP or AP. See the structure in (28) for details on how the parallel between copular sentences and vocative structures must be understood.

In the following section we present the conclusions that must be drawn from this study and the predictions to be inferred from them.

5. Conclusions and predictions

The conclusions of this paper can be formulated as follows:

- C1. A structural distinction should be made between “true” and “fake” vocatives.
- C2. Three types of complex vocatives (i.e., identity, identificational, and predicational) can be distinguished.

Let us now evaluate the predictions made from these conclusions.

Predictions from C1:

1. We expect to find vocative particles with “true” vocatives, in which the particle specifies the vocative nominal expressions, but we do not expect them to be likely with “fake” vocatives, since in the latter no adjacent [Spec,Head] relationship is fulfilled. This is exactly what we find in examples such as (7), (8), (9), and (10) above, in comparison to (12), (20) and (21). Examples (8c’,d’), repeated here, are well-formed because they are structured in two prosodic units, one for the particle and one for the DP, and the particle does not specify the DP.

- (8) c’. *Ei, ##el Joan!*
PART the Joan
- d’. *Eh, ##el noi ros.*
PART the boy blond

2. Full definite and indefinite expressions are not expected as “true” deictic vocatives because they are not heads. This prediction is borne out.

- (8) c. **Ei el Joan!*
PART the Joan
- d. **Eh el company!*
PART the fellow
- e. **Eh un(s) company(s)!*
PART {a, some} fellow(s)

3. Full NPs that have a [N A] structure are not expected either in “true” vocatives because they are not heads. This prediction is also confirmed, as shown in (28).

- (28) **Ei noi guapo!*
 PART boy handsome

4. Bare singulars and bare plurals must be distinguished from singular and plural indefinites in that they can move to Voc^o and be interpreted as deictic (i.e., they provide a property of the individual identified as the addressee, either a singular entity or a set of individuals). See the contrast between the data in (9) and (8e).

- (9) a. *Ei tio! M'agrada la samarreta que portes.*
 PART pal me.likes the T-shir that wears
 ‘Hey, man! I like your T-shirt.’
 b. *Ei nois! Calleu!*
 PART boys shut
 ‘Hey, boys! Shut up!’

- (8) e. **Eh un(s) company(s)!*
 PART {a, some} guy(s)

5. Two different interpretations must be associated with the bare plurals in (29a-a’) (deictic vs. predicational), and also with the nominals in (29b-b’) (deictic vs. merely referential; Coene et al. 1999: ex.(26)) and (29c-c’) (deictic vs. generic; Schaden 2010: ex.(18a-b)).

- | | |
|---|---|
| (29)a. <i>Nois, veniu aquí!</i>
boys come here | a’. <i>Vosaltres, nois, veniu aquí!</i>
you boys come here |
| b. <i>Amis, partons tout de suite.</i>
friends let’s.leave straight away | b’. <i>Allons, les amis.</i>
let’s.go the friends |
| c. <i>Françaises, français!</i>
French.FEM French | c’. <i>Les français!</i>
the French |

Predictions from C2:

6. In identificational vocatives we expect recursivity of DPs because it is expected that several DPs can occur in Spec,DP position. This prediction is also borne out by the data. See (30).

- (30)a. *Tu, el Joan, vés-te’n!*
 you D Joan go.CL.CL
 ‘You, Joan, go away!’
 b. *Tu, el Joan, el Joan Ripoll, vés-te’n!*
 you D Joan D Joan Ripoll go.CL.CL

7. In identificational vocatives we expect a 2P pronoun to be followed by an appositive nominal. This is exactly what we find in the possessive vocative pattern characteristic of Swedish (Corver 2008).

- (31) *Du, din idiot, borde vara försiktigare i framtiden.*
 you your idiot should be careful.COMPAR in future.the
 (Corver 2008: ex. (33a))

8. In predicational vocatives neither bare nominals nor bare adjectives move to D^o since they are not referential, but they cannot move to Voc^o either since they are not deictic and this position is already filled by the 2P pronoun. Let me remind the reader

that the structures postulated for (32) were given in (27c,d) respectively, which show that below the D° a NP or AP constrains the predicational interpretation.

(32) Tu, {*noi, desgraciat*}!
you boy bastard

(27)c. [VocP [Voc° *tu*_i] [DP [D° *t*_i] [NP [N° *noi*]]]]

d. [VocP [Voc° *tu*_i] [DP [D° *t*_i] [NP [N°] [AP [A° *desgraciat*]]]]]]

9. “True” vocatives can be arguments of nominal (and adjectival) predicates in predicational complex vocatives (contra Coene et al. 1999: note 1). Thus, in (32) the 2P pronoun is the subject-external argument of the bare predicate, regardless of whether it is nominal or adjectival.

10. A final prediction has to do with the sequence *You linguists* in English. I would like to propose a reinterpretation of the structure that should be attributed to this sequence.¹² When *you* is the head of VocP, the internal syntax of this sequence is predicted to be the same as the one corresponding to *you idiot!*¹³ Syntactically, it should be noted that these two complex vocative sequences are associated with a predicational vocative structure, in spite of the fact that the nominal heads are semantically different: a predicate of a set of entities in the first case and a gradable predicate (among which evaluative vocatives should be included) in the second case (Espinal 2011).

My analysis of this sequence consists in assuming that *you* is a pronoun that has moved from D° to Voc°, the subject of the complex structure according to (24). On the other hand, *linguists*, as predicate and head of the predicational NP, has moved from N° to Num°. This structure is represented in (33)

(33) [VocP [Voc° *you*_i] [DP [D° *t*_i] [NumP [Num° *linguists*_j] [NP [N° *t*_j]]]]]]

By contrast, the English sequence *You the linguists* corresponds to an identificational vocative. As before, *you* is assumed to move from D° to Voc°, the subject of the complex vocative. The predicate definite DP is postulated to occur in the [Spec,DP] position complement of Voc°, a position from which it identifies the referent of the vocative head. See (34).

(35) [VocP [Voc° *you*_i] [DP [DP [D° *the*] [NumP [Num° *linguists*_j] [NP [N° *t*_j]]]]] [D° *t*_i]]]

To sum up, in this paper I have focused on the internal syntactic structure of vocatives. I have postulated a distinction between “true” and “fake” vocatives, which can combine in complex vocatives in different ways. The output of this combination is that an identity, identificational, or a predicational type of vocative can emerge.

References

Cabré, Teresa and Maria del Mar Vanrel 2008. Accent i entonació en els vocatius de l'alguerès. Paper presented at the XXXV *Col·loqui de la Societat d'Onomàstica*, Sala del Consell Comunal, l'Alguer (Sardenya). May 10th and 11th.

Cabredo-Hofherr, Patricia 2009. Definiteness markers in vocatives. Ms. CNRS/Paris8, Paris.

Chierchia, Gennaro 1998. Reference to kinds across languages. *Natural Language Semantics* 6, 339–405.

Coene, Martine, D'Hulst, Yves and Tasmowski, Liliane 1999. Romance vocatives and the DP hypothesis. Paper presented at *CSSP*, Paris.

- Corver, Norbert 2008. Uniformity and diversity in the syntax of evaluative vocatives. *Journal of Comparative German Linguistics* 11, 43-93.
- Cowper, Elisabeth and Daniel Currie Hall 2009. Argumenthood, pronouns, and nominal feature geometry. In: Jila Ghomeshi, Ileana Paul and Martina Wiltschko (eds.), *Determiners*, 97-120. Amsterdam: John Benjamins.
- Daniel, Michael and Andrew Spencer 2009. The vocative - an outlier case. In: Andrej Malchukov and Andrew Spencer (eds.), *The Oxford Handbook of Case*, 626-634. Oxford: Oxford University Press.
- Déchainé, Rose-Marie and Martina Wiltschko 2002, Decomposing pronouns. *Linguistic Inquiry* 33. 3, 409 – 442.
- D'hulst, Yves, Coene, Martine, and Liliane Tasmowski 2007. The Romance vocative and the DP hypothesis. In: A. Cunita, C. Lupu and L. Tasmowski (eds.), *Studii de lingvistica si filologie romana. Hommages offerts à Sanda Reinheimer Rîpeanu*, 200-211. Bucharest: Editura Universitatii din Bucuresti.
- Espinal, M.Teresa 1991. The representation of disjunct constituents. *Language* 67.4, 726-762.
- Espinal, M.Teresa 2011. Bare nominals, bare predicates: properties and related types. Paper presented at the *Workshop on the syntax and semantics of nounhood and adjectivehood*. Barcelona: Universitat Autònoma de Barcelona. March 24th and 25th.
- Floritic, Franck 2000. De l'impératif italien *sii* (*sois!*) et de l'imperatif en général. *Bulletin de la Société de Linguistique de Paris* XCV, 227-266.
- Floritic, Franck 2010. Vocatives and the 'Minimal Word' syndrome. Paper presented at the *Vocative!* Workshop. Bamberg: University of Bamberg. December 10th and 11th.
- Higgins, Francis Roger 1979. *A pseudo-cleft construction in English*. New York: Garland.
- Hill, Virginia 2007. Vocatives and the pragmatics-syntax interface. *Lingua* 117, 2077-2105.
- Longobardi, Giuseppe 1994. Reference and proper names: a theory of N-movement in syntax and logical form. *Linguistic Inquiry* 25.4, 609-665.
- Moro, Andrea 2003. Notes on vocative case. A case study in clause structure. In: Josep Quer and Jan Schroten (eds.), *Romance languages and linguistic theory 2001*, 247-261. Amsterdam: John Benjamins.
- Payne, John and Rodney Huddleston 2002. Nouns and nouns phrases. In: Rodney Huddleston and Geoffrey K. Pullum (eds.), *The Cambridge Grammar of the English Language*, 323-424. Cambridge: Cambridge University Press.
- Rizzi, Luigi 1997. The fine structure of the left periphery. In: Liliane Haegeman (ed.), *Elements of Grammar: Handbook of Generative Syntax*, 281-337. Dordrecht: Kluwer.
- Roberts, Ian 2010. Agreement and Head Movement: Clitics, Incorporation and Defective Goals. Cambridge MA.: MIT, LI monograph.

Schaden, Gerhard 2010. Vocatives. A note on addressee-management. *University of Pennsylvania Working Papers in Linguistics*, 16, 176-185.

Stavrou, Melita 2009. Vocative! Ms. Aristotle University of Thessaloniki.

Vallduví, Enric 1990. The informational component. PhD Dissertation. University of Pennsylvania. Published by Garland, 1992.

Zamparelli, Roberto 1995. Layers in the Determiner Phrase. PhD Dissertation. University of Rochester. Published by Garland, New York, 2000.

Zwicky, Arnold M. 1974. Hey, Whatsyourname!. *CLS* 10, 787-800.

Notes

* This paper has benefited from comments and discussion with A. Gallego, V. Hill, C. Picallo, and M. Stavrou. Different versions were presented at the *Vocative!* Workshop (Bamberg, December 2010), *Journée d'étude Langues avec et sans articles* (Paris, March 2011), and International Workshop on *Sentence-Initial Bare Nouns in Romance* (Tuebingen, May 2011).

Financial support for this research has been obtained from the Spanish Ministerio de Ciencia e Innovación (HUM2006-13295-C02-01FILO) and the Generalitat de Catalunya (2009SGR-1073). The author also acknowledges an ICREA Acadèmia award.

¹ See also Hill (2007:2078), who states explicitly this same goal.

² In the discussion that follows I have omitted reference to NumberP to keep my analysis simple, but I assume that the canonical structure of nominal expressions in languages with number morphology and determiners has the form in (i) (Chierchia 1998; Longobardi 2001; Zamparelli 1995).

(i) [DP D [NumP Num [NP N]]]

³ The data under study are Catalan unless otherwise specified.

Most examples correspond to “call” vocatives (Zwicky 1974), although the analysis proposed here can be extended to vocatives that serve other “communicative” purposes.

⁴ These particles are to be distinguished from exclamative particles (Catalan *ah, oh*).

⁵ Moro (2003: 253) notes that vocatives “display anomalous behaviour both syntactically (absence of the article, presence of an interjection which immediately precedes the noun phrase, selective referential capacities) and phonologically (truncation and stress retraction).” Several studies deal with specific phonological processes (truncation, prosodic contours) that apply to vocative forms in languages both with and without articles (Floriciu 2000, 2010; Cabré & Venrell 2008; Daniel & Spencer 2009; and others).

⁶ It might also be the case that vocatives are reduced to the Voc particle, and that a postsentential nominal in the informational coda (Vallduví 1990) must be analysed as a topic constituent. See (i).

- (i) a. Ei! M'agrada la samarreta que portes, *tio*.
 PART me.likes the T-shir that wears pal
 ‘Hey! I like your T-shirt, man!’
 b. Ei! Calleu, *nois!*
 PART shut boys
 ‘Hey! Shut up, boys!’
 c. Eh! Què tal, *canalla?*
 PART how that kids
 ‘Hey! How are things, kids?’

⁷ According to Moro (2003: 258) a VocP is a full noun phrase containing both N° and D° projections that may display anomalous behaviour both syntactically and phonologically. He assumes that the VocP is hosted in the Spec of the head projected by a Voc° feature governing Force°. See (i).

(i) C° = ...Voc° > Force° > (Top° > Foc° > Top° >) Fin°...

However, as will be shown shortly, it is not clear how this structure can be integrated with the internal structure of VocP, which is characterized by the fact that it selects DPs. See (1) in the text.

According to Hill (2007: 2078) the VocP is a functional RoleP in which pragmatic Role markers select DPs and, depending on their morphological status, they merge either in the head or in the specifier of RoleP. She also postulates that RoleP is in the specifier position of a Speech Act Phrase above ForceP, whose head is assumed to be the particle *hai(de)* in Romanian.

(ii) [SAP RoleP_{hearer} [SA' [*hai*] [ForceP]]]

When considering Catalan this structure must be simplified, since no item like *hai* seems to exist in this language.

According to Stavrou (2009: 9) the specifier position of the pragmatic category Pragmatic Role Phrase_{addressee} is the locus of a VocP of direct address. She postulates that the Voc particle is generated inside Voc°, whose complement is a NumberP, and that the second person addressee is generated in PR°.

- (iii) [PR_{addressee} [VocP [Voc' [Voc°][NumP]]] [PR_{'addressee} [PR°_{addressee}][ForceP]]]

This analysis predicts a syntactic order such as (iv), which is ungrammatical in Catalan.

- (iv) *Ei estudiants vosaltres.
PART students you.PL.INFORMAL

It also predicts that the particle is not a specifier and that the complement of Voc is not a DP, predictions that appear to be wrong when considering the data in Catalan.

⁸ We refer the reader to the notion of structural deficiency as the key to motivate the series of head-movements postulated here (Roberts 2010).

⁹ An argument in support of a distinction between a second person determiner and a second person pronoun is given in (i). Notice that in (i a), *vosaltres nois* is the subject of the sentence, and *vosaltres* is a D° head that cannot be specified by a vocative particle; by contrast, in (i b) *vosaltres* is a pronoun in Voc° that allows both a vocative particle in [Spec,VocP] position and a predicative nominal in complement position.

- (i) a. (*Ei), vosaltres_d nois us penseu que aprovareu sense estudiar.
PART you.PL.INFORMAL boys CL think that pass without studying
b. Ei, vosaltres_p, nois, que us penseu que aprovareu sense estudiar?
PART you.PL.INFORMAL boys that CL think that pass without studying
'Hey, you boys, do you think that you will pass (the exams) without studying?'

See below, mainly (24), for details about the structure to be attributed to (i b).

¹⁰ I thank E. Ciutescu (p.c.) for discussion of Romanian data, and for providing me with examples (18b-c).

¹¹ I owe this example to A. Mardale (p.c.).

¹² Previous analyses include Déchaine and Wiltschko (2002: str.(33a)), who postulate that *you* is a D° and *linguists* is a complement N°. For these authors φP is an intermediate functional projection that intervenes between N and D and encodes φ-features (where φ-features include number and gender, and in some cases person). See (i).

- (i) [DP [D° *you*] [φP [φ°] [NP [N° *linguists*]]]]

See also Payne and Huddleston's (2002) distinction between *you* determiner and *you* pronoun. An argument in support of the claim that *you* starts as a Determiner is that it can be preceded by *all*.

A different proposal is given by Cowper and Hall (2009: str.(28a)), who analyse *you* as the head of φP (in this case a functional projection that introduces an index), modified by #P (which introduces number features).

- (ii) [φP [φP *you*] [#P *linguists*]]

¹³ See Corver's (2008) study of the syntax of evaluative vocatives.